

GD&T Challenge #2

This is the second of three challenges dealing with the mechanical bolted flange joint shown below. Study the design intent and dimensioning scheme as shown. The fasteners are not key locating features, they are only clamping the flanges together.

Using the solution from Challenge #1, determine how small the clearance hole could be made. What changes would be needed to give more tolerance in manufacturing the part? No changes can be made to the hardware size, tapped hole requirements, or the .281 nominal diameter.

Fastener: .250-20 UNC X 1.00 Long. (fully thread fastener). Use nominal (Basic) fastener values if values are needed from the table shown below and base values on three significant digits. Assume no positional error between head of fastener and threaded feature.

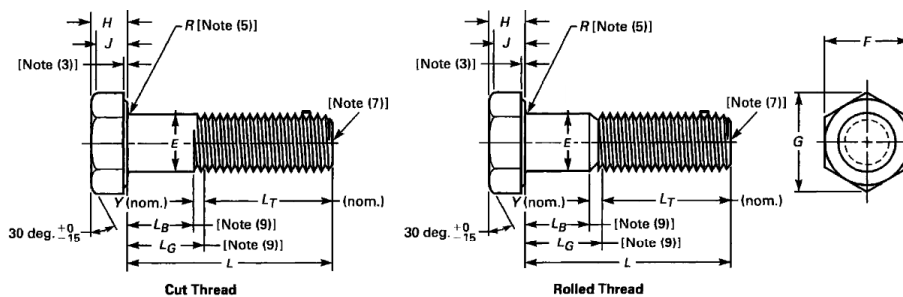

TABLE 4 DIMENSIONS OF HEX CAP SCREWS

Nominal Size or Basic Product Diameter [Note (15)]	E		F			G		H			J	L _T		Y	Circular Runout of Bearing Surface FIM [Note (3)]
	Body Diameter [Note (6)]		Width Across Flats			Width Across Corners [Note (2)]		Head Height			Wrenching Height [Note (2)]	Thread Length for Screw Lengths [Note (9)]		Transition Thread Length [Notes (9), (10)]	
	Max.	Min.	Basic	Max.	Min.	Max.	Min.	Basic	Max.	Min.		Min.	6 in. and Shorter		
1/4 0.2500	0.2500	0.2450	7/16	0.438	0.428	0.505	0.488	5/32	0.163	0.150	0.106	0.750	1.000	0.250	0.010

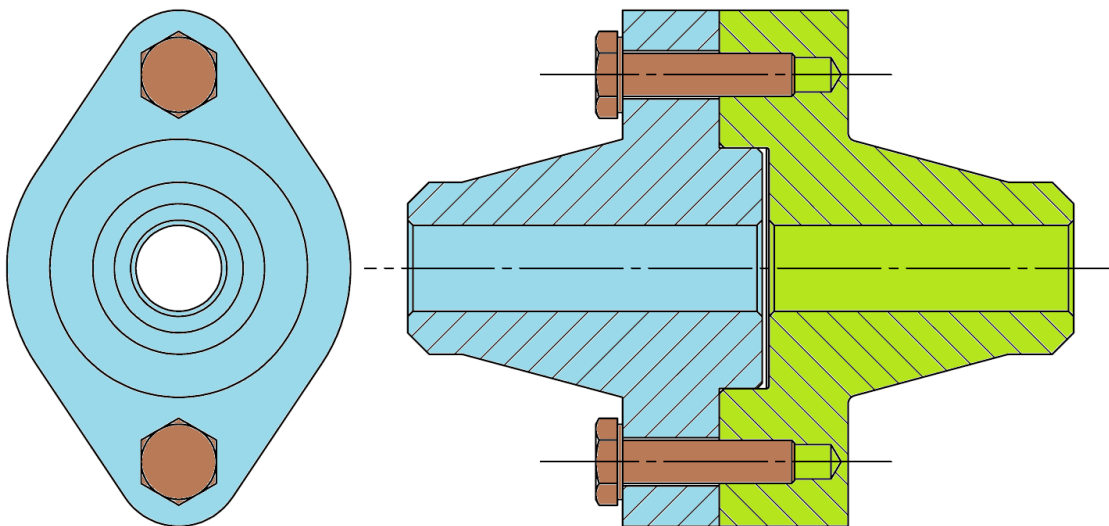

Figure 1, Weld Flange Assembly

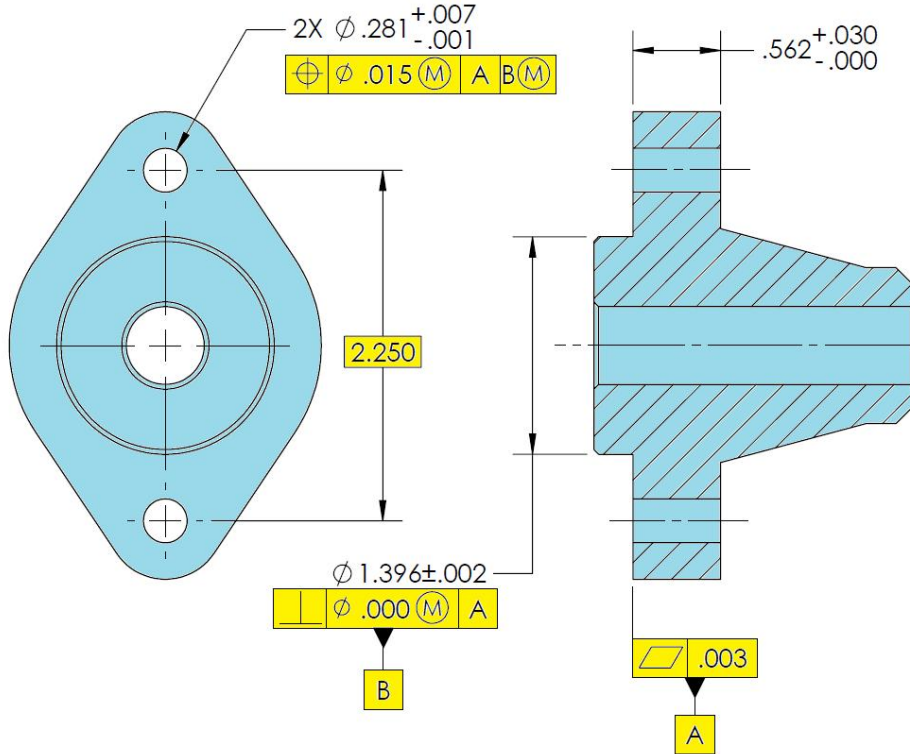

Figure 2, Male Weld Flange

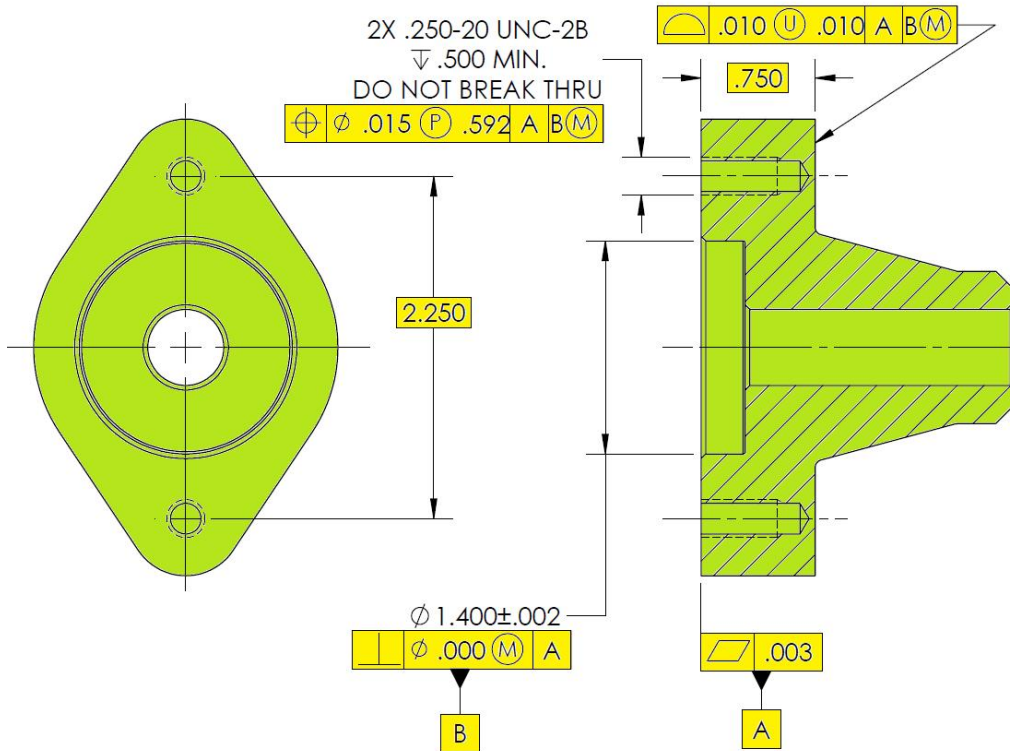

Figure 3, Female Weld Flange